

Modular composite construction allows for infinite combinations of shapes maintaining high production rates.

Lightweight and high resistance.

Can incorporate large battery & payload section.

Excellent buoyancy & stability.

Easy to deploy & service.

Reduced Painting maintenance.

Cost effective & environmentally friendly.

Customizable lifting eyes to better suit your needs.

Highlighted features:

- Light weight
- Easy handling
- High Durability
- Customizable
- Low maintenance
- I.A.L.A. compliant
- Impact resistant



The Marker Guardian S2400SMHS is a multi-purpose buoy that can be adapted to perform a range of tasks limited only by the costumers needs. The lowered center of mass assures extra stability providing better working conditions for maintenance operations and less turbulence for sensitive equipment. S2400HS has a large volume which allows it to be equipped with a considerable amount of batteries, and a large surface that can support the installation of solar panels. This energy can be then used to recharge UAV's operating nearby or maintain surveillance operations of ports entries, feed water quality monitoring devices, etc.

Water quality monitoring devices can be easily installed and readings can be taken either dependent or independently. Probes will function accurately and reliably in fresh, salt or brackish water.

The MG S2400SMHS is fully built in composite, withstanding impacts, solar exposure, salt water and corrosion exemplary. Each section is laminated using UV-stabilized, isophthalic polyester resin reinforced with Kevlar* and glass fibers to obtain maximum durability, crash resistance and water impermeability. With thicknesses ranging from 10 up to 15mm this structure is rigid durable and reliable.

S2400HS and can be upgraded with up to 32 sensors, communication antennas, all protected inside the structure without loss of efficiency. Its' simplified modular structure and electronics allows for easy upgradability and maintenance. From low cost energy efficient sensors to high precision devices can be installed to meet specific client needs.

This Guardian can generate alerts and send them to mobile devices via Wi-Fi or Bluetooth. For monitoring of several devices radio frequency transmitter is used connecting many devices to 1 central server. This allows for a real time monitoring of multiple parameters, such as: dissolved oxygen, salinity, water level, temperature, pressure, position or live video.

The fully composite structure assures a rust free, low maintenance lifespan. No part of the structure requires painting at any stage of the product's life span. The MG can be supplied in all I.A.L.A. colors.

*optional

Marker Guardian S2400SMHS

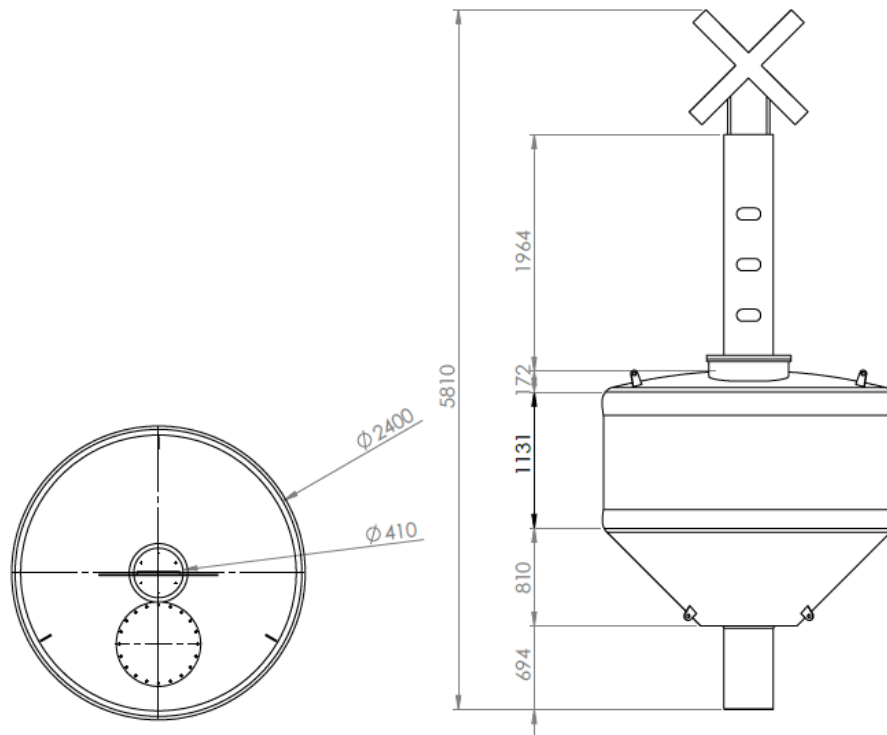

Wave Guardian S2400SMHS

General Characteristics	
Available Colors	Yellow, Red, Green as per I.A.L.A. recommendations
Focal Plane Height (mm/in)	2800/110
Total Float Volume (L/gal)	7778/2055
Nominal Freeboard (mm/in)	1300/51
Freeboard, Minimum (mm/in)	300,0/11,8
Draft, Maximum (mm/in)	1500/59
Nominal Draft (mm/in)	1370/54
Reserve Buoyancy (Kg/lb)	1443/3181
Visual Area (m ² /ft ²)	3,8/40,9
Water Area (m ² /ft ²)	6,8/73,2
Ballast (Kg/lb)	361/796
Maximum Mooring Load (Kg/lb)	433/955
Safe Working Load, 1point (Kg/lb)	10000/22046
Safe Working Load, 2points (Kg/lb)	20000/44092
Submergence (Kg.cm ⁻³ /lb.in ⁻³)	1,05/2,31
Physical Characteristics	
Material	Isophthalic NPG Polyester resin reinforced with Kevlar and glass fiber; 316-grade SS fixtures
Height (mm/in)	5810/229
With (mm/in)	2400/95
Wall Thickness (mm/in)	7/0,28
Mass (Kg/lb)	805/1774
Product Life Expectancy	>20 years
Certifications I.A.L.A.	Surface colors compliant to I.A.L.A. E-108
Intellectual Property Trademarks	Marker Guardian is a registered trademark of Composite Solutions, Lda.
Quality Assurance	ISO 9001:2008
Warranty	1 year
Standard Equipment	
	Data logger with Bluetooth connectivity with upgradability up to 32 sensors
	32Gb of data storage
	LCD display
	Adjustable measuring time intervals
Optional Equipment	
	Dissolved Oxygen Kit
	Electrical conductivity, temperature & depth sensor Kit
	GPS
	Temperature, humidity, wind & pressure Kit
	Surveillance camera/motion sensor Kit
	Solar Panels
	Upgraded battery capacity
	Status light
	Wi-Fi, VHF, Iridium, RF, GPRS, 3G & 4G

